

# Subwoofer

## PRO-ENC8

**Congratulations!** You have purchased a high quality powered subwoofer. Your subwoofer has been developed to provide you with pleasing accurate bass in your music system or home theater sound system.

The PRO-ENC8 is a pre-engineered, high-performance enclosure for custom installation of our 8" subwoofers and speaker systems. Made from high quality MDF and finished in non-reflective black textured vinyl, the ENC-816LP's shallow depth allows for installation in standard 2x4 walls and ceilings with 16" (or larger) on-center joists.

The PRO-ENC8's internally braced sealed (acoustic suspension) design is acoustically tuned for our 8" subwoofers. This type of design provides a high degree of subwoofer control, especially under high power applications, allowing modern power amplifiers with DSP or equalization to safely drive our subwoofers at high volume. Equipped with high-quality gold-plated spring-loaded binding posts which will accept standard banana plugs or bare wire up to 6 AWG (4.8mm).

With proper installation and setup, the ENC-816LP will enhance the user's home theater and music listening experience while providing minimal intrusion into a home's décor. This manual provides information about the ENC-816LP enclosure and details the basic installation procedure.

### BOX CONTENTS



Enclosure



Cut-Out Template



Foam Strips (6)



Manual



Short Brackets (4)



Screws (16):  
1/2" (13mm)



Screws (8):  
3/4" (19mm)

### SPECIFICATIONS

**Height:** 29-9/16" (750mm)                      **Width:** 13-1/2" (343mm)  
**Depth:** 3-3/8" (85.5mm)                      **Volume:** 0.56 ft<sup>3</sup> (16 Liters)  
**Speaker Cutout Dimensions:** 8-5/8" (219mm) Dia. x 3 7/8" (99mm) Deep\*

\* This mounting depth assumes the use of 1/2" (13mm) wall material or optional ENC-IRA8 adapter. A minimum wall thickness of 1/2" (13mm) is required for our subwoofers. The final mounting depth is determined by the thickness of the wall surface. The maximum allowable wall thickness is 1.5".

### SPECIFICATIONS

A number of compatible accessories for the ENC-816LP expand its range of applications. These accessories include:

- in-room adapter for free standing use.
- Pre-painted black square grilles to match enclosure.
- Extended length brackets for special mounting considerations.
- A selection of plugs and wall jack plates to optimize any installation and finish.



In-Room Adapter



Long Brackets



Square, Black Magnetic Grille



www.ditopro.com

# Subwoofer

P-1200

## PRO-ENC8 PLACEMENT

This section covers the placement of subwoofers only. Please reference the instructions that came with your speakers for information on their placement.

Since the performance of any subwoofer(s) in a room, whether in-wall, in-ceiling, or freestanding, is influenced by their location, careful consideration should be given to placement. Ideally, they should be located where they will produce the best low bass performance at the primary listening area and they should also blend in as much as possible with the room design and decor. That's why the PRO-ENC8 is such a great solution. By building the subwoofer(s) into the walls or ceilings, and/or placing them behind, beneath, or beside furniture, they can truly be hidden from view yet provide deep, rich bass performance.

It is beyond the scope of this manual to discuss all of the aspects of subwoofer placement, however, this section contains information to help guide your decision. Please contact a professional for assistance if you are uncomfortable with the planning or installation process.

In most small home theater systems, 2 subwoofers are recommended, each in an PRO-ENC8. For larger rooms and/or higher output applications, 4 or more subwoofers are recommended.

At the most fundamental level, the task of a subwoofer is to energize the room with clean, clear, low frequency sound. This happens most efficiently when the subwoofer(s) is located in a room's corners, (where three surfaces meet). For this reason, one of the best places for the PRO-ENC8 is within 36 inches of a corner (see options A, D & G in Fig. 1).

If possible, avoid placing them immediately adjacent to openings such as hallways and entries to other rooms since energy is lost to these areas and can, in some cases, generate unwanted resonances.

Another placement option is to install the subwoofers a distance of  $\frac{1}{4}$  the room width from the sides (Options B, C, & E). This works well when the walls are symmetrical, parallel, and constructed of similar composition to the left and right of the subwoofers. Though the subwoofers will be less efficient at transferring energy to the room at these locations (compared to corners), the bass will likely be more uniform at more listening positions across the width of the room. This arrangement is likely the best option when Auto Room Calibration systems are not employed.

If the listening room is rectangular and has a ceiling parallel to the floor, then four subwoofers can effectively be arranged in a central rectangular pattern in the ceiling (Option C). Of the suggested locations, this location is the least efficient at transferring energy to the room. However, the advantage is that it can help to provide more uniformity in the bass reproduction within the boundaries of the subwoofers. This option is likely best for mid-room seating where there are multiple rows and where Auto Room Calibration systems are not employed.

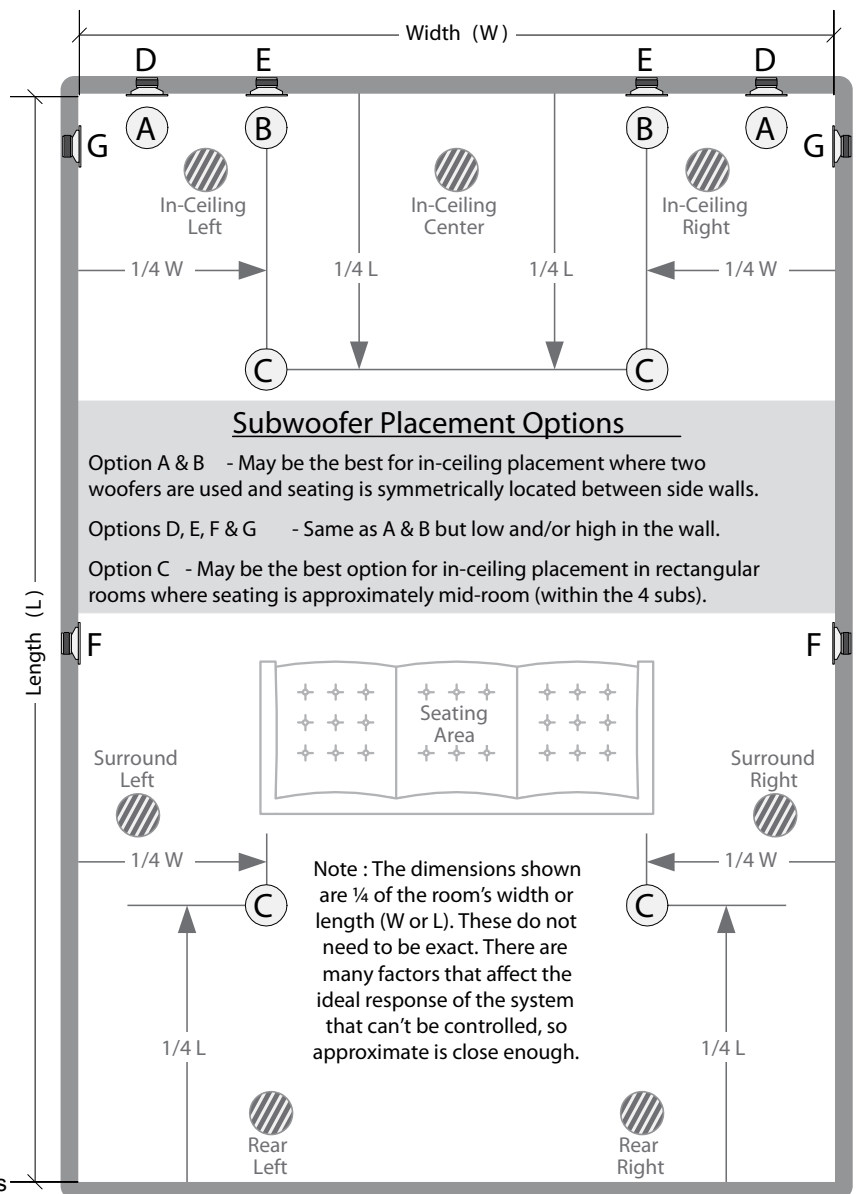

Fig. 1



# Subwoofer

P-1200

Option F is also a consideration because the subwoofers are close to the seating area, but it lacks the advantages of corner loading and  $\frac{1}{4}$  wavelength spacing. Another note on placement: Mirroring the placement of Options A, B, D, E, & G at the back of the room is a very effective way to increase the system output.

Finally, if the application is a modern home theater, consider implementing the Auto Room Calibration system on your AV receiver.

## INSTALLATION

Note: The previous section provides information to aid in determining the best placement for subwoofers.

Once the location(s) are established, run wire of sufficient gauge to the chosen location(s). 16 gauge minimum wire size is recommended for distances of less than 50 feet (15m). For distances in excess of 50 feet (15m) 14 gauge or larger is recommended. Follow all applicable codes for wire rating. Most regions require a CL2 or CL3 rated wire. It is beyond the scope of this manual to detail the wire installation. If you are uncomfortable doing this yourself, contact a qualified professional.

It is recommended that each enclosure be independently wired back to the amplifier location. In other words, the wires should not be shared with any other speakers.

Once the wires have been run, install the enclosure as described in the following pages. It is important to note that you cannot install the subwoofer driver yet, as the drywall will provide the necessary spacing in order to effectively mount the subwoofer.

## INSTALLATION - IN ROOM (Free Standing)

The PRO-ENC8 has been engineered to also perform as a low-profile free standing subwoofer enclosure via optional ENC-IRA8 adapter. If you intend to use the enclosure in this manner, we encourage you to experiment with placement, as options are nearly unlimited. The ENC-816LP may be oriented in any way you see fit so long as there is a minimum of 25mm (1") of space between the front of the subwoofer and the nearest solid surface. The same placement rules previously described apply to in-room (freestanding) subwoofers.

Having multiples, such as two or four ENC-816LP's will help to optimize and smooth the in-room response of your subwoofers by reducing peaks and nulls caused by standing waves and also lower distortion.

1. Remove the paint shield (both disk and sleeve) from the enclosure opening.
2. Place the ENC-IRA8 adapter over the opening with the foam-faced surface against the face of the enclosure.
3. Place a strip of thin adhesive-backed foam around the backside of the mounting flange of the subwoofer along with two short strips on the back of the magnet assembly as shown in Fig. 4.
4. Connect the two-conductor wire that is provided within the enclosure to the input terminals of the speaker. Use care to ensure that the proper polarity is observed.
5. Install the subwoofer as directed by its installation manual. Ensure that the wire is kept clear of the back of the magnet assembly so that the magnet will fit into the cutout at the back of the enclosure. Turn the four Phillips screws until the subwoofer is snug.
6. Place the grille over the subwoofer. Pre-painted black square grilles are available to match the enclosure. White grilles can be painted following the instructions provided with the speaker(s) / subwoofer(s).
7. If placed on a hard floor, it is suggested that you apply foam strips to the side that will make contact with the floor



Shown with Square Grille

# Subwoofer

P-1200

## INSTALLATION - IN-WALL / IN CEILING

The enclosure is designed to mount easily without the need to simultaneously hold it in place while attaching the hardware. This simple process involves locating and installing the mounting screws within the wall, attaching the brackets to the enclosure, connecting the wire, hanging the enclosure and securing it in position. These steps are shown below:

1. Determine the location of speaker hole above the floor or from wall, as measured to the center of the hole and record it below (refer to measurement 'A' in Fig. 2).

- Distance from floor or wall to speaker hole center: \_\_\_\_\_

2. Add 22" (560mm) to measurement 'A'. This is the distance to the upper mounting screws. Subtract 9.5" (240mm) from measurement 'A'. This is the distance to the lower mounting screws.

**Note:** The upper mounting screws are 31.5" ±1/8" (800mm ±3mm) above the lower mounting screws.

Example: If the speaker hole is to be 16" from the floor or wall, then the upper & lower screws will be 38" & 6.5" away. 16+22=38, 16-9.5=6.5

- Upper bracket distance: \_\_\_\_\_

- Lower bracket distance: \_\_\_\_\_

3. Mark the upper and lower mounting screw locations using the option below that fits your installation (refer to measurement 'B' in Fig. 2).

- **WALL INSTALLATION ONLY:** Mark the distance of the mounting screw locations 1" (25mm) behind the face of the two (2) studs.

- **CEILING INSTALLATION ONLY:** Mark the distance of the mounting screw locations 1/2" (13mm) behind the face of the two (2) joists.

4. Install the four (4) #8x3/4" (3x19mm) mounting screws leaving about an 1/8" to 1/4" (3mm to 6mm) gap between the head and the wood stud/joist (refer to measurement 'C' in Fig. 2).

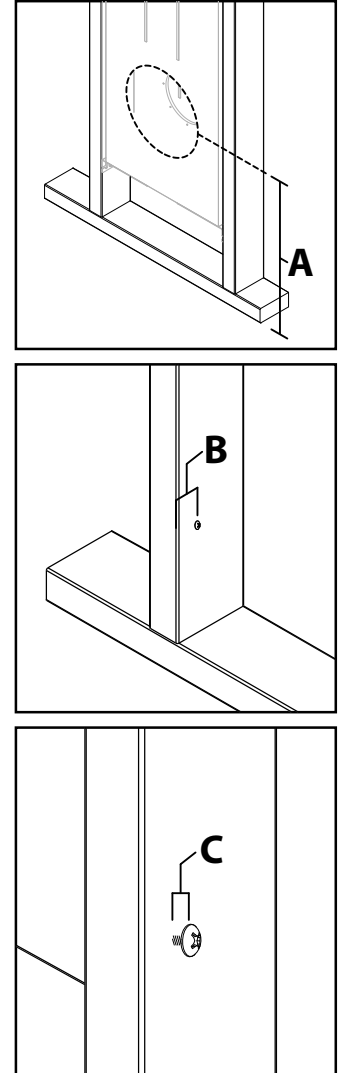
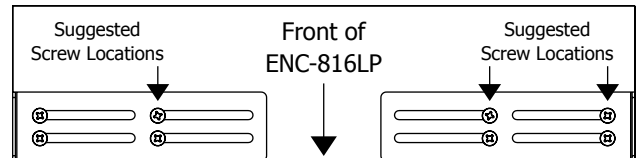

Fig. 2

5. Attach the four (4) mounting brackets to the top and bottom of the ENC-816LP enclosure using the sixteen (16) #8x1/2" (3x13mm) mounting screws. Do not fully tighten the screws at this time since it will be necessary to slide the brackets.

The screws can be drilled into the enclosure without predrilling. Use the short brackets as a template, aligning the outside of the tab and long edge of the brackets flush with the side and front edges of the enclosure as shown. The screw locations can be adjusted to fit your mounting location. Optional long brackets, are available.



6. Determine the distance of the speaker hole from one of the studs or joists and subtract 6.75" (171mm) from this number. This is the bracket offset for one side. Using this offset, secure the upper and lower brackets on one side of the enclosure by tightening the screws.

- Distance from center of speaker hole to stud: \_\_\_\_\_

- Bracket Offset: \_\_\_\_\_



www.ditopro.com

# Subwoofer

7. Measure and record the distance between the studs/joists at both the upper and lower mounting screw locations.

- Upper bracket distance: \_\_\_\_\_
- Lower bracket distance: \_\_\_\_\_

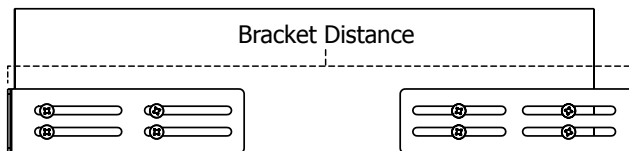

Adjust and secure the brackets on the opposite side of the enclosure so that the outside of the mounting tabs are slightly less than the distance (i.e. 1/16" (1mm) total) between the studs or joists.

8. Attach foam strips to the front and back of the enclosure by removing the protective backing from the adhesive side and pressing onto the enclosure. The exact placement is not critical but should be in the approximate regions shown in Fig. 3.

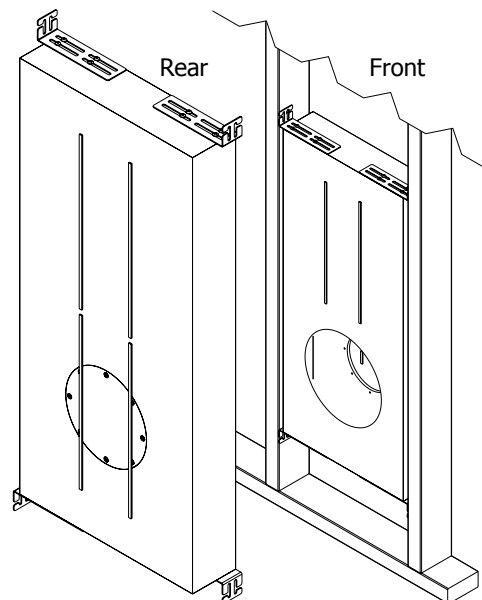

Fig. 3

9. Suspend the enclosure from the studs or joists using the option below that fits your installation.

- **WALL INSTALLATION ONLY:** Hook the top set of brackets to the upper screws and then guide the slots of the lower set of brackets onto the lower screws, lifting the enclosure slightly as needed.

- **CEILING INSTALLATION ONLY:** Hook the bottom set of brackets to the lower screws and swing the enclosure up so that the upper brackets just pass the upper screws. Slide the enclosure toward the upper screws, guiding the slots of the upper set of brackets onto the upper screws.

10. Tighten the four (4) mounting screws, securing the brackets to the studs.

11. If you have not yet done so, attach the speaker wire to the input terminals ensuring that you have made a good electrical connection. **DO NOT FORGET THIS STEP!** Use care to ensure that the proper polarity is observed.

12. **DRYWALL INSTALLATION:** Prior to installation ensure the cut-out template is installed in the enclosure opening. The drywall should be cut with care. This can be done with a rotary saw (Roto zip®) or other appropriate tool at the time of drywall installation. A paint shield is provided with instructions to guide the drywall installer to cut the hole.

13. **INSTALLATION OF SPEAKER OR SUBWOOFER:** Once the wall has been finished, you may remove the cut-out template that covered the hole in the enclosure, pull outward on the disk and sleeve and discard both.

For subwoofer applications, it is suggested that you place a strip of thin adhesive-backed foam around the backside of the mounting flange along with two short strips on the back of the magnet assembly as shown in Fig. 4.

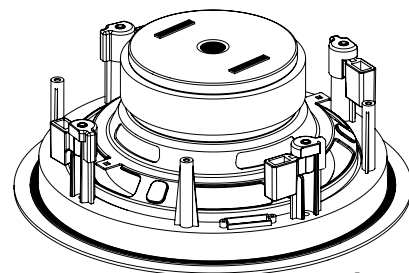

Fig. 4

Connect the two-conductor wire that is provided within the enclosure to the input terminals of the speaker. Again, use care to ensure that the proper polarity is observed.

Install the speaker or subwoofer as you would in any conventional installation. Ensure that the wire is kept clear of the back of the magnet assembly so that the magnet will fit into the cutout at the back of the enclosure.